

Electric Gas Cooler Series EC[®]

ECM-ExII

 II 3 G Ex ec nC IIC T4 Gc

 Class I, Div. 2, Groups A/B/C/D, T4

Instruction Manual

Doc: M_ECM-EX_EN_

Version 1.02.02



**Dear customer,**

Thank you for buying our product. In this instruction manual you will find all necessary information about this M&C product. The information in the instruction manual is fast and easy to find, so you can start using your M&C product right after you have read the manual.

If you have any question regarding the product or the application, please don't hesitate to contact M&C or your M&C authorized distributor. You will find all the addresses in the appendix of this manual.

For additional information about our products and our company, please go to M&C's website www.mc-techgroup.com. There you will find the data sheets and manuals of all our products in German and English.

This Operating Manual does not claim completeness and may be subject to technical modifications.

© 06.2022 **M&C TechGroup** Germany GmbH. Reproduction of this document or its content is not allowed without permission from **M&C**.

ECM® is a registered trade mark.

Version: 1.02.02

Content

1	General information	4
2	Declaration of conformity	4
3	Safety instructions	5
4	Warranty	6
5	Warning signs and definitions	6
6	Information and safety instructions for using the cooler in hazardous areas	8
7	Information and safety instructions for using the cooler	9
8	Introduction	10
8.1	Serial number	10
8.2	Power supply	10
8.3	Patent references	10
9	Technical Data	11
9.1	For basic cooler ECM-ExII without heat exchanger	11
9.2	Options for basic cooler ECM-ExII	12
10	Application	13
11	Description	14
12	Function	15
13	Receiving and storing of the device	16
14	Installation instructions	16
15	Mounting	17
15.1	Tubing connections	17
16	Electrical connections	19
17	Start-up	20
18	Closing down	21
19	Maintenance	21
19.1	Adding and replacing the heat exchangers	22
19.2	Cleaning the fins of the condenser	23
19.3	Maintenance of the optional mounted peristaltic pump(s), type SR25.2	23
19.3.1	Mounting instructions for SR25.2 peristaltic pump (optional)	23
19.3.2	Replacing the pump tubing	24
19.3.3	Replacing contact pulleys and springs	26
19.3.4	Cleaning the pump head	26
20	Operating of the built-in electronic temperature controller	27
20.1	Changing the set value	27
20.2	Changing the temperature alarm window	27
21	Trouble shooting	28
22	Spare parts list	29
23	Appendix	30

List of illustrations

Figure 1	Application example of the ECM-ExII	13
Figure 2	ECM-2G ExII	14
Figure 3	Diagram of the heat exchanger function	15
Figure 4	Position of the gas and condensate connections	17
Figure 5	Electrical connections, alarm contacts	19
Figure 6	SR25.2: Mounting distance between front panel and pump motor	24
Figure 7	Replacing the pump tubing	25
Figure 8	Front view of the temperature controller	27
Figure 9	Sample gas output dew point as a function of gas flow at 60 °C inlet dew point	30
Figure 10	Circuit diagram ECM-ExII (Drawing-No.: 2456-5.01)	31



Head Office

M&C TechGroup Germany GmbH ♦ Rehhecke 79 ♦ 40885 Ratingen ♦ Germany
Telephone: 02102 / 935 - 0
Fax: 02102 / 935 - 111
E - mail: info@mc-techgroup.com
www.mc-techgroup.com

1 General information

The product described in this manual has been built and tested in our production facility.

All M&C products are packed to be shipped safely. To ensure the safe operation and to maintain the safe condition, all instructions and regulations stated in this manual need to be followed. This manual includes all information regarding proper transportation, storage, installation, operation and maintenance of this product by qualified personnel.

Please follow all instructions and warnings closely.

Please read this manual carefully before commissioning and operating the device. If you have any questions regarding the product or the application, please don't hesitate to contact M&C or your M&C authorized distributor.

2 Declaration of conformity



The product described in this operating manual complies with the following EU directives:

ATEX-Directive

The product described in this manual is produced in accordance with the EU directive for devices and protection systems for appropriate use in hazardous areas 2014/34/EU.

RoHS Directive

The requirements of the RoHS2 ('Restriction of Hazardous Substances 2') directive 2011/65/EU and its annexes are met.

EMV-Instruction

The requirements of the EU directive 2014/30/EU 'Electromagnetic compatibility' are met.

Low Voltage Directive

The requirement of the EU directive 2014/35/EU 'Low Voltage Directive' are met.

Declaration of conformity

The EU Declaration of conformity can be found in the annex of this manual. It can also be downloaded from the **M&C** homepage or directly requested from **M&C**.

3 Safety instructions

Please follow these safety directions and instructions regarding installation, commissioning and operation of the equipment:

- Read this manual before commissioning and operating the product. Please make sure to follow all safety instructions.
- Attention must be paid to the requirements of the Type Examination Certificate (see appendix): 16 ATEX E 055 X.
- Installation and commissioning of electrical devices must be carried out only by qualified skilled personnel in compliance with the current regulations.
- The installation and commissioning of the device must conform to the requirements of VDE 0100 (IEC 364) 'Regulations on the Installation of Power Circuits with Nominal Voltages below 1000 V' and must be in compliance with all relevant regulations and standards.
- For use in hazardous area, observe the relevant national and international directives and regulations.
- Before connecting the device, make sure to compare the supply voltage with the specified voltage on the product label.
- Protection against damages caused by contact with parts carrying high voltages: Disconnect the power supply before opening the device for access. Make sure that all external power supplies are disconnected.
- Operate the device only in the permitted temperature and pressure ranges. For details please refer to the technical data sheet or manual.
- The device needs to be mounted inside a housing or cabinet with protection class IP54 or higher, complying with the IEC 60079-0 standard.
- Installation, maintenance, inspections and any repairs of the devices must be carried out only by qualified and skilled personnel in compliance with the current regulations.

4 Warranty

In case of a device failure, please contact immediately M&C or your M&C authorized distributor.

We have a warranty period of 12 months from the delivery date. The warranty covers only appropriately used products and does not cover the consumable parts. Please find the complete warranty conditions in our terms and conditions.

The warranty includes a free-of-charge repair in our production facility or the free replacement of the device. If you return a device to M&C, please be sure that it is properly packaged and shipped with protective packaging. The repaired or replaced device will be shipped free of delivery charges to the point of use. Do not send the heat exchangers with the device.

5 Warning signs and definitions



Danger

The 'Danger' warning sign indicates that death, serious injury and/or significant material damage will be the consequence, if the appropriate precautions should not be taken.



Warning

The 'Warning' warning sign indicates that death, serious injury or damage to property may occur if the relevant precautionary measures are not observed.



Caution

The 'Caution' warning sign indicates that slight personal injury can occur if the appropriate safety precautions are not observed.

Caution

'Caution' indicates that damage to property can occur if the appropriate safety precautions are not observed.

Attention

'Attention' indicates that an unintended result or situation can occur if the corresponding information is not taken into account.



Note

'Note' indicates important information relating to the product or highlights parts of the documentation for special attention.

Qualified personnel

'Qualified personnel' are experts who are familiar with the installation, mounting, commissioning and operation of these types of products.



These are important information about the product or parts of the instruction manual referring to operating in hazardous areas.



High voltages!
Protect yourself and others against damages which might be caused by high voltages.



Toxic!
Acute toxicity (oral, dermal, inhalation)! Toxic when in contact with skin, swallowed or inhaled.



Corrosive!
These substances destroy living tissue and equipment upon contact. Do not breathe vapors; avoid contact with skin and eyes.



Wear protective gloves!
Working with chemicals, sharp objects or extremely high temperatures requires wearing protective gloves.



Wear safety glasses!
Protect your eyes while working with chemicals or sharp objects. Wear safety glasses to avoid getting something in your eyes.



Wear protective clothes!
Working with chemicals, sharp objects or extremely high temperatures requires wearing protective clothes.

6 Information and safety instructions for using the cooler in hazardous areas

The compressor cooler ECM-ExII is suitable for using in hazardous area of zone 2 (see Ex-certificate).

The explosion proof protection for both models is:

230 V / 115 V:  II 3G Ex ec nC IIC T4 Gc
 (Registration-No.: BVS 16 ATEX E 055 X)
 230V / 115V: Class I, Div. 2, Groups A/B/C/D,
 T4 / CAN/CSA-C22.2 No 61010.1-4; No. 213-M87



The certification of the cooler was done by the DEKRA EXAM BBG Prüf- and Zertifizier GmbH.

For detailed information and a copy of the certificate see appendix.

Installation and operating of the cooler has to be done corresponding to the conditions specified in the Ex-certificate (see appendix). Only in this case the reliability of the operation in the hazardous area can be guaranteed.

Any modification of the standard configuration of the device with parts, which are not approved by M&C and not explicitly specified for usage in explosive atmospheres, will void the Type Examination Certificate. This also refers to any repair work and service using parts which are not M&C approved and not specified for usage in explosive atmospheres.

Please don't hesitate to contact M&C or your M&C distributor if you have any questions about parts, service and repair work of the device.



Disconnect power supply before opening the device for access.

Make sure that all external power supplies are disconnected.

This also applies to any external control circuits which may be connected.

Pay close attention to the requirements of the Type Examination Certificate in the appendix of this instruction manual: 16 ATEX E 055 X.



Only carry out work on the controller, when the process and area is declared as an explosive free zone. An explosive free zone is free of explosive atmosphere.



7 Information and safety instructions for using the cooler



Warning

Inhalation hazard possible, if using toxic or asphyxiant gases!



Purge cooler with inert gas or air before opening! If the cooler is used for toxic gas or asphyxiant (oxygen-displacing) gas, it needs to be purged with inert gas or air before opening. Follow closely all relevant occupational safety regulations during operation..



Warning

Disconnect power supply before opening the device for access.
Make sure that all external power supplies are disconnected.



Do not carry out any work at the sensor while potentially explosive atmosphere is present.

The process and the environment of the device needs to be explosion-free (explosion-free zone) during any maintenance or repair work. A zone is declared as explosion-free zone, if it is free of explosive atmosphere.



Aggressive condensate is possible.



Wear protective gloves and protective glasses!



Wear proper protective clothing!

8 Introduction

The **M&C ECM-ExII** gas cooler unit is designed to operate whenever there is moisture interference in the sample gas.

Lowering the sample gas temperature to a very low and stable dew point prevents condensate built-up in the analyser and avoids unstable measurements, because of water vapour cross-sensitivity or volumetric errors.

The ECM-ExII is certified for appropriate use in the specified Ex zones noted in the Type Examination Certificate.



Only operate the ECM-ExII according the specifications stated in this instruction manual and in the extended manufacturer documents.

8.1 Serial number

The type plate with the serial number is located at the right hand side panel of the cooler housing (wall mounting version).

Please refer to this serial number if you have any questions about your **ECM-ExII** or if you need to order spare parts or consumables.

8.2 Power supply

The cooler can be operated with AC voltage in the range of 110 V to 240 V, 50 to 60 Hz.



8.3 Patent references

The **M&C** sample gas cooling device is patented under the following patent number:

- Germany 199 57 052
- USA 6.477.851

9 Technical Data

9.1 For basic cooler ECM-ExII without heat exchanger

Gas cooler series EC®	version ECM-1 ExII	version ECM-2 ExII
Part No.	02K7600x (a)**	02K7610x (a)**
Amount of possible heat exchangers	1 heat exchanger	2 heat exchangers
Sample outlet dewpoint	Range of adjustment: +2 °C ... +7 °C [+35.6 °F...+44.6 °F], factory setting: +5 °C [+41 °F]	
Dew point stability	At const. conditions: < ±0.1 °C [±0.18 °F]	
Sample inlet temp. in EX zone with T3	***Max. +180 °C [356 °F] if cooler is mounted in EX zone with temperature class T3	
Sample inlet temp. in EX zone with T4	***Max. +120 °C [248 °F] if cooler is mounted in EX zone with temperature class T4	
Sample inlet dew point	***Max. +80 °C [176 °F]	
Gas flow rate	***Max. 250 l/h	
Ambient temperature	+10 to +50 °C [+50 to +122 °F]	
Storage temperature	-20 to +60 °C [-4 to +140 °F]	
Total cooling capacity	40 W at 10 to 50 °C [+50 to +122 °F] ambient temperature	
Ready for operation	< 15 min	
Power consumption	Max. 200 VA (start up current at 230 V = 2.5 A; at 120 V = 4.5 A)	
Main power connection	230 V / 115 V, 50 Hz/60 Hz (a): -15 % / +10 %	
Electrical connections	Terminals: 6-12 mm , cable gland: 2 x M20 x 1.5	
Status alarm	1 free configurable status alarm with 2 potential free change-over contacts, alarm point: < 2 °C [35.6 °F] and > 8 °C [46.4 °F] factory setting) contact rating 250 VAC, 2 A; 500 VA; 50 W	
Explosion proof protection		230 V / 115 V: Ex II 3G Ex ec nC IIC T4 Gc (Registration-No.: BVS 16 ATEX E 055 X)
		240V / 120V: Class I, Div. 2, Groups A/B/C/D, T4 CAN/CSA-C22.2 No 61010.1-04 and No. 213-M87
Electrical safety	EN	EN 61010
		CAN/CSA-C22.2 No.61010.1-04 UL Std. No. 61010-1(2 Edition)
System of protection	IP20 (EN 60529)	
Case colour	RAL 9003	
Method of mounting	Wall mounting	
Dimensions	270 x 270 x 316 mm [10.63" x 10.63" x 12.44"] W x H x D	
Weight	12 kg [26.46 lbs] / 13.5 kg [29.76 lbs] (version: 230 V / 115 V)	

** Option

*** Maximum values in technical data must be rated in consideration of total cooling capacity at 25 °C [77 °F] ambient temperature and an outlet dew point of 5 °C [41 °F].

9.2 Options for basic cooler ECM-ExII

Heat exchanger type	ECM-1G	ECM-1PV	ECM-1SS	ECM-2G	ECM-2PV	ECM-2SS
Part No	93K0140	93K0170	93K0160	97K0100	97K0110	97K0115
Material of heat exchanger	Borosilicate glass	PVDF	st. steel 316Ti	Borosilicate glass	PVDF	st. steel 316Ti
Max. gas flow rate	250 NI/h	250 NI/h	250 NI/h	150 NI/h	150 NI/h	150 NI/h
Sample gas pressure abs.	Max. 2 bar (3 bar) ¹	Max. 3 bar	Max. 10 bar	Max. 2 bar (3bar) ¹	Max. 3 bar	Max. 10 bar
Sample gas connection	GL 18 for Ø 6 mm a.d. tube*	G1/4" i	G 1/4" i oder 1/4" NPT**	GL18 for Ø 6 mm a.d. tube*	Tube Ø 6 mm*	Tube Ø 6 mm*
Condensate connection	GL 25 for Ø12 mm tube* Ø 8 mm or Ø 10 mm**	G3/8"i	G3/8"i o. 3/8"NPT**	GL 25 for Ø 12 mm tube* Ø8 mm or Ø10 mm**	G3/8"i	G 3/8" i o. 3/8"NPT**
ΔP at max. flow	1 mbar	1 mbar	1 mbar	1 mbar	1 mbar	1 mbar
Stagnant space approx.	100 ml	100 ml	100 ml	40 ml	25 ml	30 ml

Peristaltic pump SR25.2	<p>1 pc. incorporated in the cooler, compl. installed, part no.: 01P9125; Novopren tubing, pumping capacity 0.3 l/h, 5 rpm, cooler weight plus 0.6 kg [1.32 lb] per pump</p> <p>⚠ The sample gas pressure is limited to 2 bar absolute</p> <p>For more information about the SR25.2 and about other tubing materials see SR25.2 manual.</p>
-------------------------	---

* Standard, other versions on request ¹ with GL connecting adapter

** Option

*** Maximum values in technical data must be rated in consideration of total cooling capacity at 25 °C [77 °F] ambient temperature and an outlet dew point of 5 °C [41 °F].

10 Application

Figure 1 shows a typical application example for an **ECM-ExII** gas cooler unit.

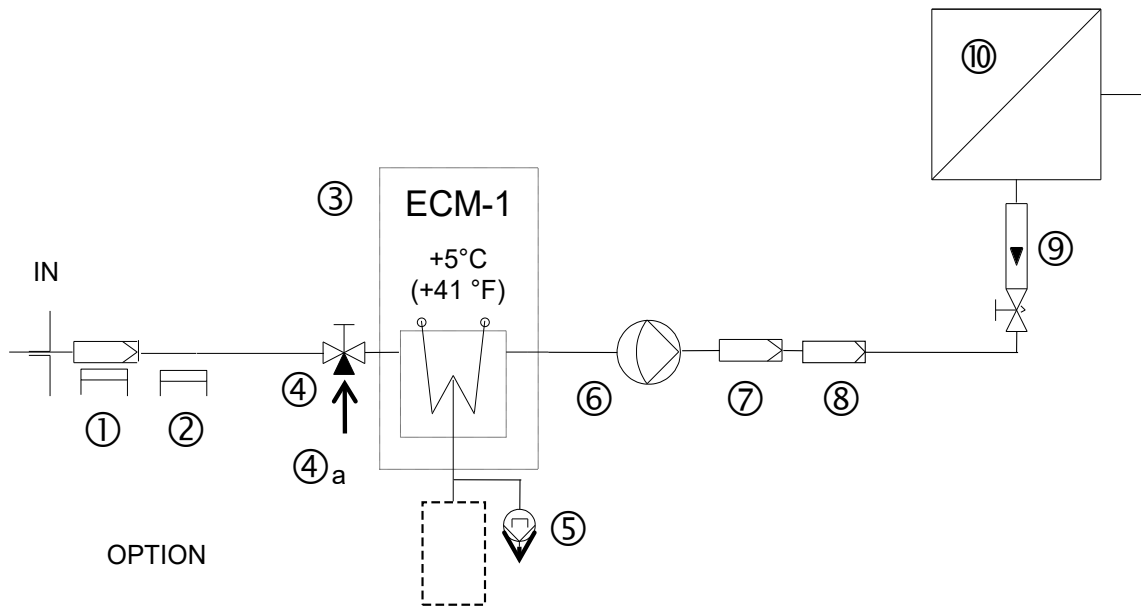

Figure 1 Application example of the ECM-ExII

- | | |
|---------------------------------|------------------------------|
| 1 : Filter sample probe SP ... | 6 : Membrane pump |
| 2 : Heated sample line | 7 : Super fine filter FP ... |
| 3 : ECM-ExII cooler | 8 : Aerosol filter CLF-5 |
| 4 : 3-way ball valve | 9 : Flow meter FM10 |
| 4a : Test gas | 10 : Analyzer |
| 5 : Peristaltic pump (optional) | |

The sample gas enters the gas sample probe ①, and via a heated sample line ② it reaches the **ECM-ExII** gas cooler ③. The gas cooler ③ cools the sample gas down to a dew point of +5 °C [41 °F]. The super-fine filter ⑦ removes solid particles from the sample gas. To enhance the operating safety of the entire system, we recommend installing a super-fine filter ⑦ with a liquid alarm sensor. If required, an aerosol filter ⑧ can be installed in-line, in front of the flow meter ⑨. The conditioned gas can now enter the analyser ⑩.



Do not use the gas cooler to extract gases or gas compositions, which could be potentially explosive without the presence of air. Do not use gases or gas compositions which can alter the relevant safety-related material properties of the cooler materials. The gas or gas composition needs to be free of particles which could cause, in combination with the materials of the gas cooler, sparks by friction or impact.



Warning

Inhalation hazard possible, if using toxic or asphyxiant gases!

Purge gas cooler with inert gas or air before opening!



If the gas cooler is used for toxic gas or asphyxiant (oxygen-displacing) gas, it needs to be purged with inert gas or air before opening. Follow closely all relevant occupational safety regulations during operation.

11 Description

Figure 2 shows the **ECM-2G ExII** cooler unit.

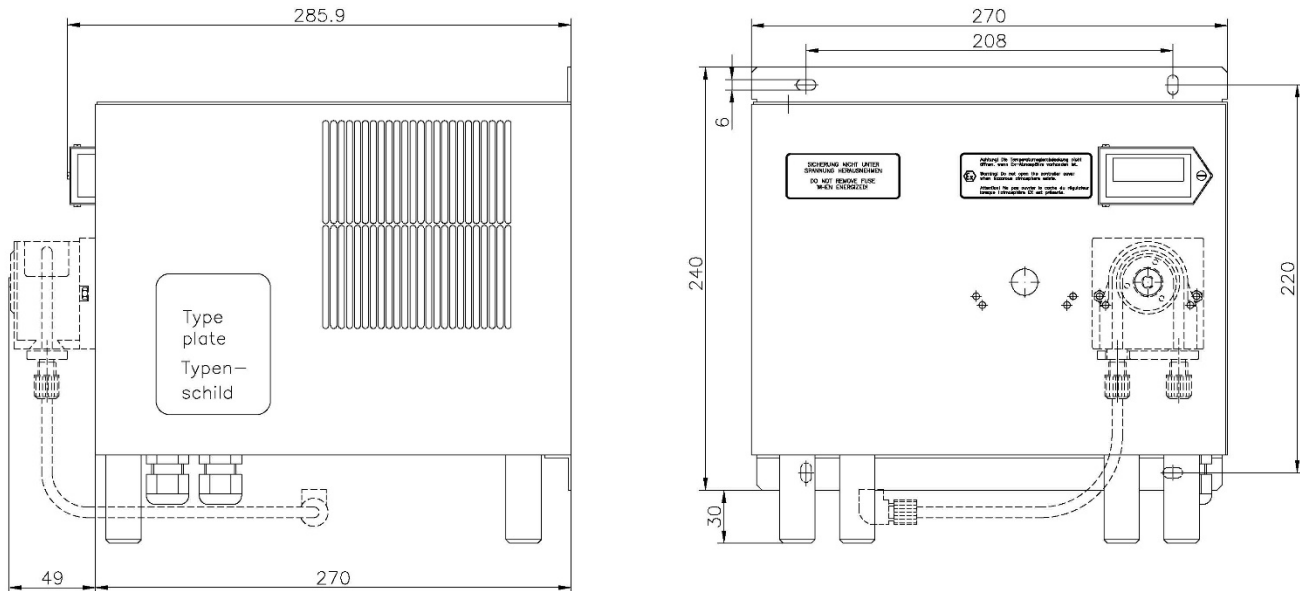

Figure 2 ECM-2G ExII

The cooler **ECM-ExII** is also suitable for wall mounting. The depth of the cooler housing is 270 mm [10.63"] without, and 316 mm [12.44"] with optionally mounted peristaltic pumps.



Warning

The cooler ECM-ExII is conform to the system protection IP20 (EN 60529). The gas cooler needs to be mounted inside a housing or cabinet with the protection class IP54 or higher, complying with the IEC 60079-0 standard. Solids and water must be prevented from entering the cooler housing through the ventilation outlets. For installation, according to NEC article 501.4 (B) (2) (conduit installation), the cable glands need to be replaced by the enclosed Conduit Hub.

On the top of the cooler housing are cut-outs for 1 or 2 heat exchangers. The sample gas inlet and out let are located at the upper part of the heat exchanger. For information about tubing connections of the heat exchangers, please see chapter 8, technical data.

The main power connector and the output contact of the status alarm can be connected at terminals X1 respectively X3, located behind the removable front panel of the **ECM-ExII** housing.

The following connections are accessible from outside the housing underneath the bottom plate:

- standard condensate outlets of the heat exchangers,
- cable bushings 2 x M20 x 1.5; clamp range 6-12 mm.

In under pressure operation the condensate will be removed either via optional **SR25.2** peristaltic pumps (pump in-line after the cooler), which are mounted into the front panel of the cooler, or with an external condensate vessel **TG.../TK...**

In over pressure operation the condensate will be removed via an automatic liquid drainer **type AD...**

12 Function

The **M&C** gas cooler type **ECM-ExII** is a compressor cooler equipped with a status alarm for safe and continuous operation.

Up to 2 Jet-stream heat exchangers made of Borosilicate glass, PVDF or stainless steel are located in a heat-insulated cooling block, where they are easy to access and to remove.

Figure 3 shows a diagram of the heat exchanger function. The compressor cooler system keeps the heat-insulated cooling block at a constant temperature of +5 °C [+41 °F].

The controlled, forced-air cooled compressor cooling system and the special design of the Jet-stream heat exchanger ensure excellent condensate pre-separation and sample gas drying.

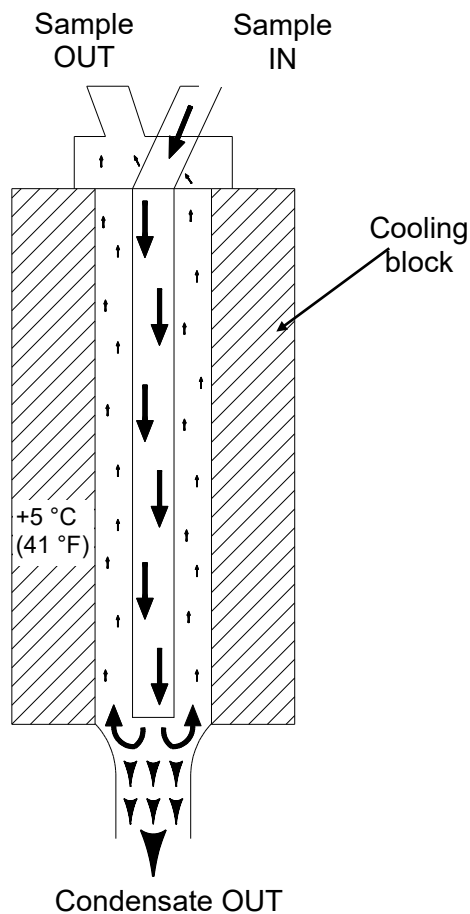

Figure 3 Diagram of the heat exchanger function

13 Receiving and storing of the device

The **ECM-ExII** gas cooler is a complete pre-installed unit.

- Please remove the **ECM-ExII** carefully from the packaging. Check the scope of the delivery specified on the delivery note. Please make sure that you have received all items stated on the delivery note.
- Please check the unit for any transport damages after receipt, and report any complaints to the transport company immediately.



Note

The cooler must be stored in a weather protected frost-free area!

The cooler should always be transported and stored in an upright position, with the equipment feet facing downwards to ensure that the oil in the closed compressor circuit cannot run out of the compressor case.

If the cooler was transported on its back by mistake, it needs to stand upright in the operating position for approx. 24 hours before switching on!

14 Installation instructions

The gas cooler needs to be mounted inside a housing or cabinet with the protection class IP54 or higher, complying with the IEC 60079-0 standard. The gas cooler needs to be installed at a location, which is frost-free in winter and adequately vented in summer. Avoid direct sun light.

The operating position for this cooler is vertical only. This is the only way to ensure proper separation and removal of condensate in the heat exchangers. During transport and installation, the cooler needs to be in an upright position, with the equipment feet facing downwards to ensure that the oil in the closed compressor circuit cannot run out of the compressor case.



Install the cooler away from heat sources in a well-ventilated area. To prevent heat build-up interfering with operation, install the device with a minimum distance of 100 mm [≈ 3.94 "] to other components.

Un-heated sample gas lines need to be installed with a declining angle towards the cooler. In this case, any built-up condensate in the gas lines can flow towards the cooler, and pre-separation of the condensate is not required.

Heated sample gas lines need to end at least 20 cm [7.874"] before the gas line reaches the cooler to make sure that the heated sample line and the cooler is thermally decoupled. This means, the last 20 cm [7.874"] of the gas lines are not isolated.

- The ECM-ExII cooler is suitable for wall mounting.

The gas cooler needs to be mounted inside a housing or cabinet with the protection class IP54 or higher, complying with IEC 60079-0 standard.

15 Mounting



Do not mount or carry out any work at the gas cooler while potentially explosive atmosphere is present.



The process and the environment of the cooler needs to be explosion-free (explosion-free zone) during mounting. A zone is declared as explosion-free zone, if it is free of explosive atmosphere.



Warning

Connect the cooler to earth (electrical bonding terminal).

The bleeder resistor needs to have an overall value of $< 10^6 \Omega$.

15.1 Tubing connections



Note

Check tubing and hose connections for any type of leakage!

The sample gas inlet and outlet are located at the upper part of the heat exchanger. For information about tubing connections of the heat exchangers, please see chapter 8, technical data.

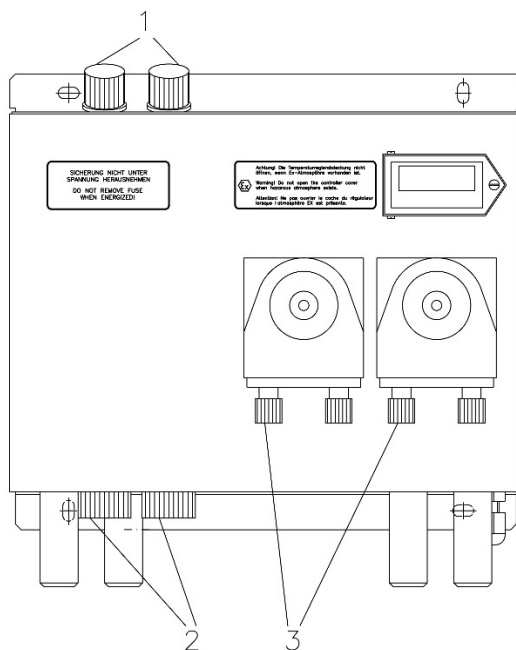

1 Gas inlet and outlet

2 Condensate outlet

3 Condensate outlet with optional mounted peristaltic pump

Figure 4 Position of the gas and condensate connections

Suitable tube and hose connectors are optional and available at **M&C** (see data sheet 11.5).



Note

Do not mix up the hose connections; the gas inlet and outlet connections of the heat exchangers are marked with arrows.

Make sure that all the connections are sealed adequately.

To ensure free removal of the condensate, do not decrease the stated diameters of the condensate removal lines!

Follow these instructions to ensure the adequate sealing of the connections:

Borosilicate glass heat exchangers with connections GL 18-6 respectively GL 25-12 (standard)

- Before assembly, check the GL coupling rings to see if the PTFE/silicon locking rings have been damaged.
- The sealing rings should be installed with the PTFE side facing the medium.

PVDF- resp. stainless steel heat exchangers with G 1/4" female resp. G 3/8" female

- The fitting tubing or hose couplings with threaded connections have to be screwed in with PTFE thread sealing tape.
- For a functional and smooth mounting, we recommend using union pieces with tapered pipe thread type R according to DIN 2999/1 in connection with suitable sealing tape or fluid.



Note

To tighten the connectors onto the PVDF or stainless steel heat exchanger, hold a wrench against the spanner flats of the bushing!

Option: stainless steel heat exchanger with NPT

- The heat exchangers with NPT threaded connectors are marked with a notch around the connecting pieces.
- The NPT thread must be screwed in with sealant or glued in with adhesive.

In the standard configuration, the tubes for condensate removal are connected directly to the heat exchangers. These protrude with the GL 25-12 tube connectors (standard, Borosilicate glass heat exchanger) respectively with G 3/8" (standard) thread joint PVDF or stainless steel heat exchanger out of the bottom plate of the cooler housing (fig.2).

The condensate removal is customer specific and depends on the type of operation:

- peristaltic pump(s) type **SR25.2** optionally mounted into the cooler housing,
- external mounted condensate vessel(s), which needs to be emptied manually respectively,
- automatic float-type liquid drainer type **AD-...** (only for over-pressure operation).



Note

If using a stainless steel heat exchangers with G 3/8" thread, the float-type automatic liquid drainer AD-SS can be directly mounted to the heat exchanger by using the threaded adapter part number FF11000 (1/2" NPT to G 3/8" female). In this case wall mounting and tubing of the AD-SS unit isn't necessary!

16 Electrical connections



Wrong supply voltage can destroy your cooler!

When connecting the equipment, make sure that the supply voltage is identical with the information provided on the model type plate!



Only carry out work on live parts when the area has been proved to be "safe". Only carry out work on the protective cover in front of the temperature controller, when the area has been proved to be "safe".



The installation and commissioning of the device must conform to the requirements of VDE 0100 (IEC 364) 'Regulations on the Installation of Power Circuits with Nominal Voltages below 1000 V' and must be in compliance with all relevant regulations and standards.

The cooler has a replaceable fuse. Because of this replaceable fuse, the installation site of the cooler needs to be equipped with a suitable external switch to switch off the main power supply.



Cooler versions with 115V resp. 120 V have a built-in transformer to generate an internal current of 230 V. This means, that the internal live parts of the device have a current of 230 V not 115 V / 120 V.



Figure 5 shows the electrical connections behind the front panel of the **ECM-ExII** housing.

For alarm incidents (over- and under-temperature), there is a user-configurable status alarm with two potential-free changeover contacts available. The alarm will be set off, when the current temperature is lower than +2 °C [+35.6 °F] or higher than +8 °C [46.4 °F] (default setting).

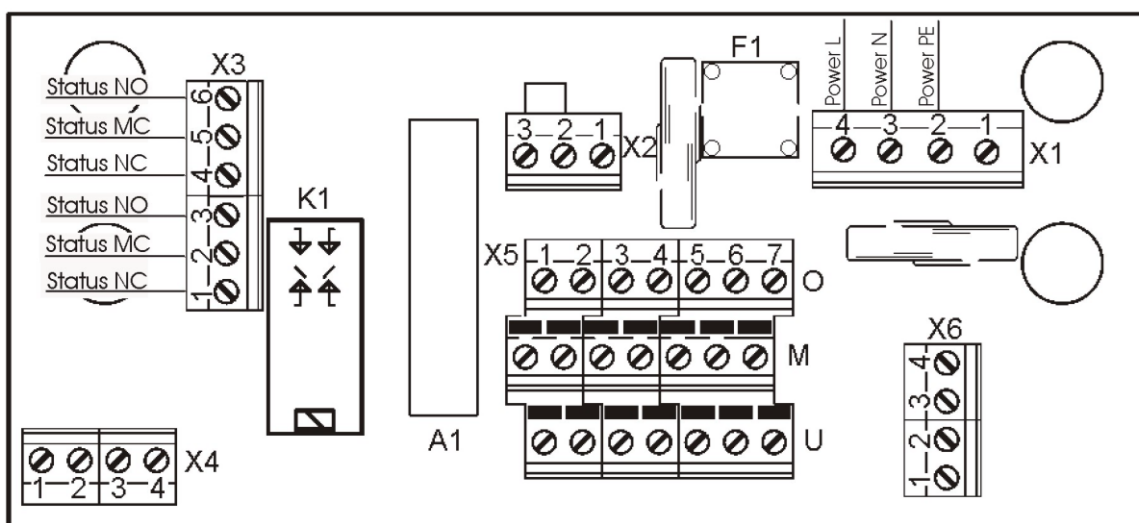

Figure 5 Electrical connections, alarm contacts

Follow these instructions to connect the status alarm and power cables:

- release the screws (7 pcs.) from the cooler hood and remove the hood;
- put the cables (6-12 mm) through one of the cable glands in the bottom plate, and connect them according to the electrical connections in Fig. 5;

17 Start-up

The controlled cooling system of the **ECMExII** permits automatic start-up of the cooler. The following description applies to a start-up at an ambient temperature of $> 8\text{ }^{\circ}\text{C}$ [$> 46.4\text{ }^{\circ}\text{F}$] only.



Only carry out any work at the gas cooler, when the process and the environment of the cooler is declared as an explosion-free zone. A zone is declared as explosion-free zone, if it is free of explosive atmosphere.



Only open the protective cover in front of the temperature controller, when the process and the environment of the cooler is declared as an explosion-free zone. A zone is declared as explosion-free zone, if it is free of explosive atmosphere.



Warning

Connect the cooler to earth (electrical bonding terminal).
The bleeder resistor needs to have an overall value of $< 10^6\ \Omega$.



Note

Before starting up the gas cooler, it must be placed in its operating position for at least two hours. The liquid inside the system may have been redistributed, and this could cause problems during operating.

The following steps should be carried out before initial start-up:

- Connect the cooler unit to the mains power supply; Make sure that the equipment is connected to the correct mains voltage, 115 V or 230 V, as shown on the type plate.
- Connect the status contact output to the measuring station;



Note

Connect the status contact output to an external sample gas pump or a solenoid valve in the gas line. In case of an alarm incident, this can protect the whole analysing system by immediate interruption of the gas supply.

18 Closing down



Note

The installation site of the cooler must be frost-free, even when the unit has been switched off!

In case of a short-term decommissioning of the cooler no special measures are required.

In case of a long-term decommissioning, we recommend to purge the cooler with inert gas or air to remove residual condensate entirely from the cooler.



Aggressive condensate is possible.



Wear protective gloves and protective glasses!



Wear proper protective clothing!

19 Maintenance

Before starting any maintenance work, make sure that any work done on the device is in compliance with all relevant regulations and standards.



Warning

Disconnect power supply before opening the device for access. Make sure that all external power supplies are disconnected.



This also applies to any external alarm or control circuits which may be connected.



Only carry out any work at the gas cooler, when the process and the environment is declared as an explosion-free zone. A zone is declared as explosion-free zone, if it is free of explosive atmosphere.



Only carry out any work at the temperature controller, when the process and the environment is declared as an explosion-free zone. A zone is declared as explosion-free zone, if it is free of explosive atmosphere.



Warning

Inhalation hazard possible, if using toxic or asphyxiant gases!



Purge cooler with inert gas or air before opening! If the cooler is used for toxic gas or asphyxiant (oxygen-displacing) gas, it needs to be purged with inert gas or air before opening. Follow closely all relevant occupational safety regulations during operation.

**Warning**

Connect the cooler to earth (electrical bonding terminal). The bleeder resistor needs to have an overall value of $< 10^6 \Omega$.

The intervals between servicing are dependent on the process and system conditions in your facility. The facility QA/QC plan should address the frequency for maintenance and should be updated based on your operations.

19.1 Adding and replacing the heat exchangers

Removal of the heat exchangers may be necessary to carry out any maintenance or repair work. The cooler does not need to be switched off while replacing the heat exchangers.

We recommend the following procedure to replace the heat exchangers:

- Release the upper gas connections and lower condensate connections;
- Pull the heat exchanger upwards and slightly rotate it out of the cooling block;

Replace the heat exchangers as follows:

- Dry and clean the opening in the aluminium cooling block with a cloth;
- Apply a thin and equal layer of thermal conductivity paste (part no. 90K0115) onto the opening;
- Apply a thin and equal layer of thermal conductivity paste over the whole surface of the heat exchangers (part no. 90K0115) to ensure good conduction of heat. It is best to close the condensate removal connections of the heat exchanger with adhesive tape to prevent any thermal conductivity paste getting into the heat exchanger;
- Lightly push and slightly rotate the heat exchanger back into the opening of the cooling block and press it to the upper block;
- Remove the adhesive tape and any surplus thermal conductivity paste;
- Reconnect the tubing.

**Note**

Do not mix up the tubing connections!
Gas outlet and gas inlet at the heat exchangers are marked with arrows!

Mounting the Borosilicate glass heat exchangers please notice:

- Check the PTFE/Silicon locking rings for damage. Assemble the locking rings with the PTFE side facing the medium, otherwise the required degree of sealing cannot be guaranteed!
- Screw-on the red GL coupling rings hand-tight by turning them to the right;

To ensure a safe connection of the sample gas or condensate tubes to the Borosilicate glass heat exchanger(s) we recommend the use of GL-couplings. Please don't hesitate to contact M&C or your M&C distributor, if you have any questions about GL-couplings.

19.2 Cleaning the fins of the condenser

Dust on the fins of the condenser reduces the cooling capacity. Therefore, it is necessary to clean the fins frequently. The following steps are recommended:

- Shut off the gas flow;
- Disconnect the power supply.
- Disconnect the tubing for gas in- and outlet;
- Unscrew the cooler hood and remove it carefully;
- Clean the fins carefully with compressed air;
- Re-install the cooler hood;
- Connect the tubing for gas in- and outlet.



Note

Do not mix up the tubing connections; the inlet and outlet connections of the heat exchangers are marked with arrows.

19.3 Maintenance of the optional mounted peristaltic pump(s), type SR25.2

Before starting any maintenance work, please make sure that any work done on the device is in compliance with all relevant regulations and standards.



Danger

Dangerous voltage!

Disconnect power supply before carrying out any type of maintenance work.



Flexible tube, conveying belt, contact pulleys and contact springs are the only parts of the pump subject to wear.

They can easily be replaced.

19.3.1 Mounting instructions for SR25.2 peristaltic pump (optional)

Make sure to mount the peristaltic pump SR25.2 to a front plate with a minimum thickness of 3.5 mm [≈ 0.138 "]. If the front plate is thinner than 3.5 mm [≈ 0.138 "], use shims to adjust spacing. The maximum thickness of the front plate is 5.5 mm [≈ 0.216 "].

The minimum distance avoids damages to the pump motor, and the maximum distance prevents the motor shaft from losing the guide inside the pump head.

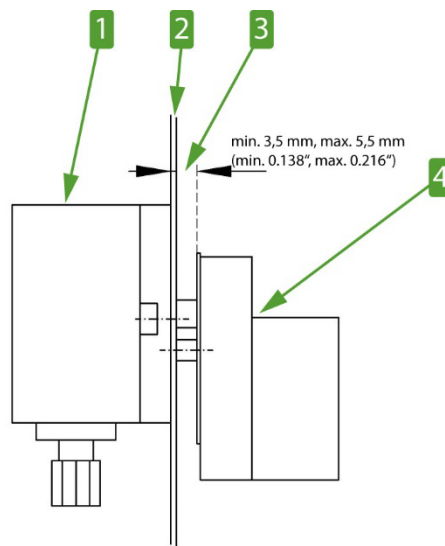

- 1 Pump head (outside the cooler housing) 2 Cooler front panel
 3 Recommended mounting distance 4 Pump motor (inside the cooler housing)

Figure 6 SR25.2: Mounting distance between front panel and pump motor



Note

For detailed mounting instructions, see the SR25.2 instruction manual. The manual is available on our website www.mc-techgroup.com.

19.3.2 Replacing the pump tubing



Aggressive condensate is possible.



Wear protective gloves and protective glasses during decommissioning, repair or cleaning of the cooler!



Wear proper protective clothing during decommissioning, repair or cleaning of the cooler!



Note

When sending the peristaltic pump to M&C customer service for repair, please indicate the type of medium pumped.

Before shipping the pump, please remove hazardous or aggressive contaminations from all parts of the pump!

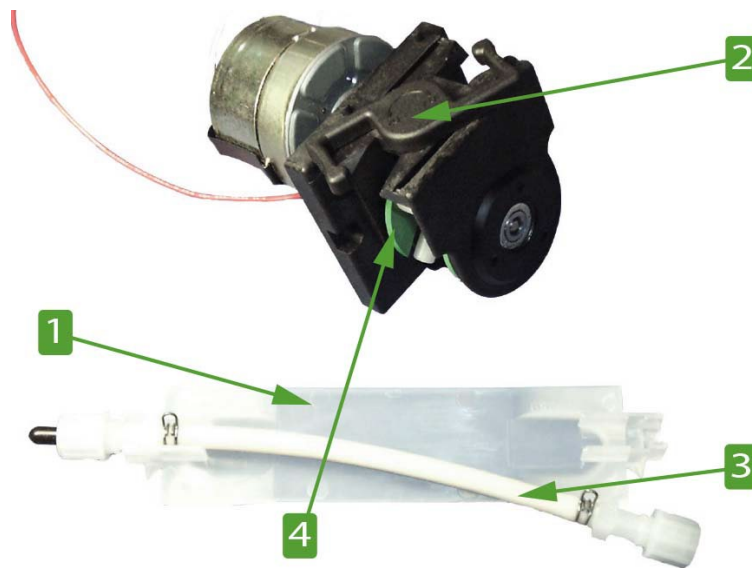

Figure 7 Replacing the pump tubing

- Disconnect the cooler from the power supply;
- Open tube connectors at the pump;
- Press conveying belt **1** at the recessed grips and turn S-bolt **2** clockwise up to limit stop;
- Remove conveying belt **1** and pull the old tubing **3** at the tube bushings out of the guides;
- Press the two contact pulleys **4** and check whether the spring pressure is still sufficient, if not, the contact springs need to be changed;
- Put the new tubing **3** with the tube connectors into the guides of the conveying belt **1**;



Note

Use only the original M&C spare parts!
Only the use of the original tubing set guarantees a perfect operation!

Never lubricate tubing!

Before mounting the pump, check all parts for contaminations and clean if necessary.

- Put the conveying belt **1** with the new tubing **3** into the dovetail guide of the pump body;
- Press conveying belt at the recessed grips and simultaneously turn the S-bolt **2** anticlockwise until it snaps;
- Turn on the pump.

19.3.3 Replacing contact pulleys and springs

- Disconnect the cooler from the power supply;
- Unscrew the screws of the pump head (metric wrench size 5.5);
- Remove the pump head from the motor shaft;

Now the driver can be removed from the pump head and is ready for maintenance.

- The removal of the springs (4 pcs.) away from the driver is possible without any tools. Therefore press together the spring and take it out of the groove in the driver, respectively out of the boring of the roll shaft. Now the roll shaft can be dismantled and the contact pulleys can be replaced.
- Assemble the pump in reversed order.



NOTE!

While mounting, make sure that the center of rotation and the driver are aligned.
Use genuine spare parts only!

19.3.4 Cleaning the pump head

- When changing flexible tubing or other parts, inspect all parts for contaminations before assembling the pump head. Clean contaminated parts if necessary.
- We recommend cleaning the parts with a dry cloth. Solvent should not be used, because it can damage the plastics and synthetic rubber parts. Use oil-free compressed air to clean the parts if available.



Aggressive condensate is possible.



Wear protective gloves and protective glasses during decommissioning, repair or cleaning of the cooler!



Wear proper protective clothing during decommissioning, repair or cleaning of the cooler!

20 Operating of the built-in electronic temperature controller



Note

Only use temperature controller with part no. 01B8365.



Only carry out any work at the temperature controller, when the process and the environment of the cooler is declared as an explosion-free zone. A zone is declared as explosion-free zone, if it is free of explosive atmosphere.

Make sure to close and secure the protective cover in front of the temperature controller after usage. The protective cover must be closed during operation.

During regular operation, the display of the temperature controller shows the current cooling temperature.

Figure 8 shows the front view of the temperature controller.



Figure 8 Front view of the temperature controller

20.1 Changing the set value

To change the set value, press the P-key for < 2 sec. The default set value of 5 °C [41 °F] appears. The set value can be changed by pressing on the two arrow keys. This value should not be set to a temperature lower than +1 °C [33.8 °F], because the heat exchanger will freeze at a lower temperature. Is the value set to a temperature higher than the ambient temperature, the cooler will not work.

20.2 Changing the temperature alarm window

The exact description of how to change the temperature alarm window can be found in the temperature controller instruction manual.

21 Trouble shooting

The following table gives an overview of possible errors and instructions for checking and repairing the unit (Applies only to the start-up period of the cooler).

Error	Possible reason	Check/Repair
Condensate in the gas outlet	Ambient temperature < 5 °C [41 °F] Cooler is overloaded Peristaltic pump doesn't work Tube of the peristaltic pump defective Cooling capacity too low (cooler is not overloaded) Motor protection switch released	Heat up the components downstream; for operating limits see technical data chapter 8; Change peristaltic pump; Change the tubing (18.3.2); Clean the fins of the condenser (18.2); Check the vent; Check the safety distance to other heated components; Secure sufficient ventilation; Thermal load caused by sample gas or high ambient temperature; Clean the fins of the condenser; for operating limits see technical data chapter 8; Let the cooler cool down before restarting it;
Gas flow is blocked	Contamination of the sample gas line	Optimize the dust pre-separation upstream of the cooler; Clean the gas lines and the cooling system;
Wrong temperature	Temperature sensor defect Temperature controller defect Leakage in the coolant circulation	Check the PT100-sensor; Check the temperature controller; Send the cooler for repair;
Cooler break-down	Power supply interrupted	Check the power supply and reconnect;  Pay attention to the relevant safety instructions!
Compressor does not work	Compressor defect; Motor protection switch defect	Send the cooler for repair;

22 Spare parts list

The replacement interval for spare parts and consumables depends on the specific operating condition of the analyzer. The quantities recommended in the following table are based on experience. Your replacement intervals will be based on your operating conditions.

Electric gas cooler ECM-ExII					
(C) Consumable parts					
(R) Recommended spare parts					
(S) Spare parts					
		Recommended quantity being in operation [years]			
Part No.	Indication	C/R/S	1	2	3
93K0140	ECP-3000 G Jet-Stream heat exchanger material: Borosilicate glass Gas connections: GL 18-6 mm Condensate: GL 25-12 mm	R	1	1	1
93K0160	ECP-3000 SS Jet-Stream heat exchanger material: SS 316 Gas connections: G 1/4" female Condensate: G 3/8" female	R	1	1	1
93K0170	ECP-3000 PV Jet-Stream heat exchanger material: PVDF (Polyvinylidenfluorid) Gas connections: G 1/4" female Condensate: G 3/8" female	R1	1	1	1
97K0100	ECM-2G Jet-Stream heat exchanger material: Borosilicate glass Gas connections: GL 18-6 mm Condensate: GL 25-12 mm	R	1	1	1
97K0110	ECM-2PV Jet-Stream heat exchanger material: PVDF (Polyvinylidenfluorid) Gas connections: 6 mm tube Condensate: G 3/8" female	R	1	1	1
97K0115	ECM-2SS Jet-Stream heat exchanger material: SS 316 Gas connections: 6 mm tube Condensate: G 3/8" female	R	1	1	1
90K0115	EC-thermal conductivity paste 50g (-40 to 140 °C [-40 to 284 °F])	E	1	1	2
90K0035	Fan ECP 230 V, 50 Hz	C	-	-	1
93K0040X	PT-100 temperature sensor for ECM	C	-	-	1
90K7015	Cooling unit, complete with compressor, vaporiser and condenser for ECM-ExII Cooling medium: R134A, power: 230 V, 50 Hz	R	-	-	-
97K0010	ECM transformer 115 V / 230 V, ... 230 VA	R	-	-	-
01B8365	Electronical PID temperature controller for ECM-Ex	S	-	-	1

Peristaltic pump SR25.2					
(C) Consumable parts					
(R) Recommended spare parts					
(S) Spare parts					
		Recommended quantity being in operation [years]			
Part No.	Indication	C/R/S	1	2	3
90P1007	Hose set ③ SR25.1 with PVDF-tube connectors 4/6 mm, standard	C	1	2	4
90P1020	Driver SR25, complete	S	-	1	1
90P1010	1 set (4 pcs) contact springs SR25 for driver	R	1	2	2
90P1045	Contact pulleys SR25 PVDF ④ for driver	S	2	4	4
90P1050	Conveying belt SR25.1 ①	S	-	1	2
90P1025	S-bolt ② SR25.1	S	-	-	1
01P1300	Peristaltic pump SR25.2, complete 230 V/115 V, 50/60 Hz	R	-	-	1
90P1031	Heat peristaltic pump SR25, complete without tube set, motor and gears	S	-	-	1

23 Appendix

- Sample gas output dew point as a function of gas flow at 60 °C inlet dew point.
- Circuit diagram ECM-ExII Drawing No.: **2456-5.01**
- Ex-certificates: ATEX, CSA
- EU Declaration of conformity



Find more product information on our home page:
www.mc-techgroup.com

- Threaded couplings for 'GL' glass connections
Document: **11.5**
- Instruction Manual Peristaltic Pump Series SR®: SR25.1, SR25.2-G, SR25.1/Ex
- Automatic liquid drain AD-SS
Document: **6.13M**
- Automatic liquid drain AD-P
Document: **6.12**
- Condensate vessel TG, TK
Document: **6.14**

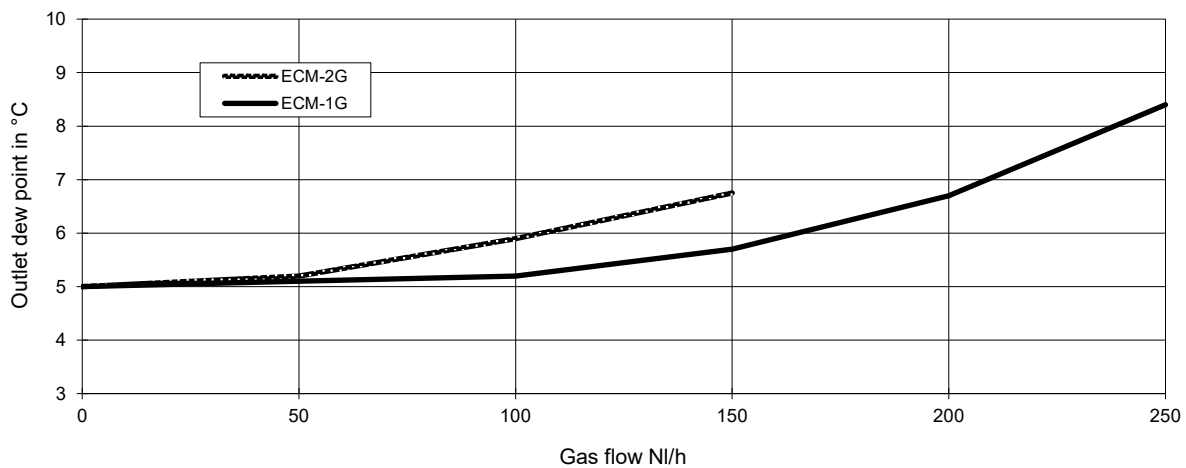

Figure 9 Sample gas output dew point as a function of gas flow at 60 °C inlet dew point

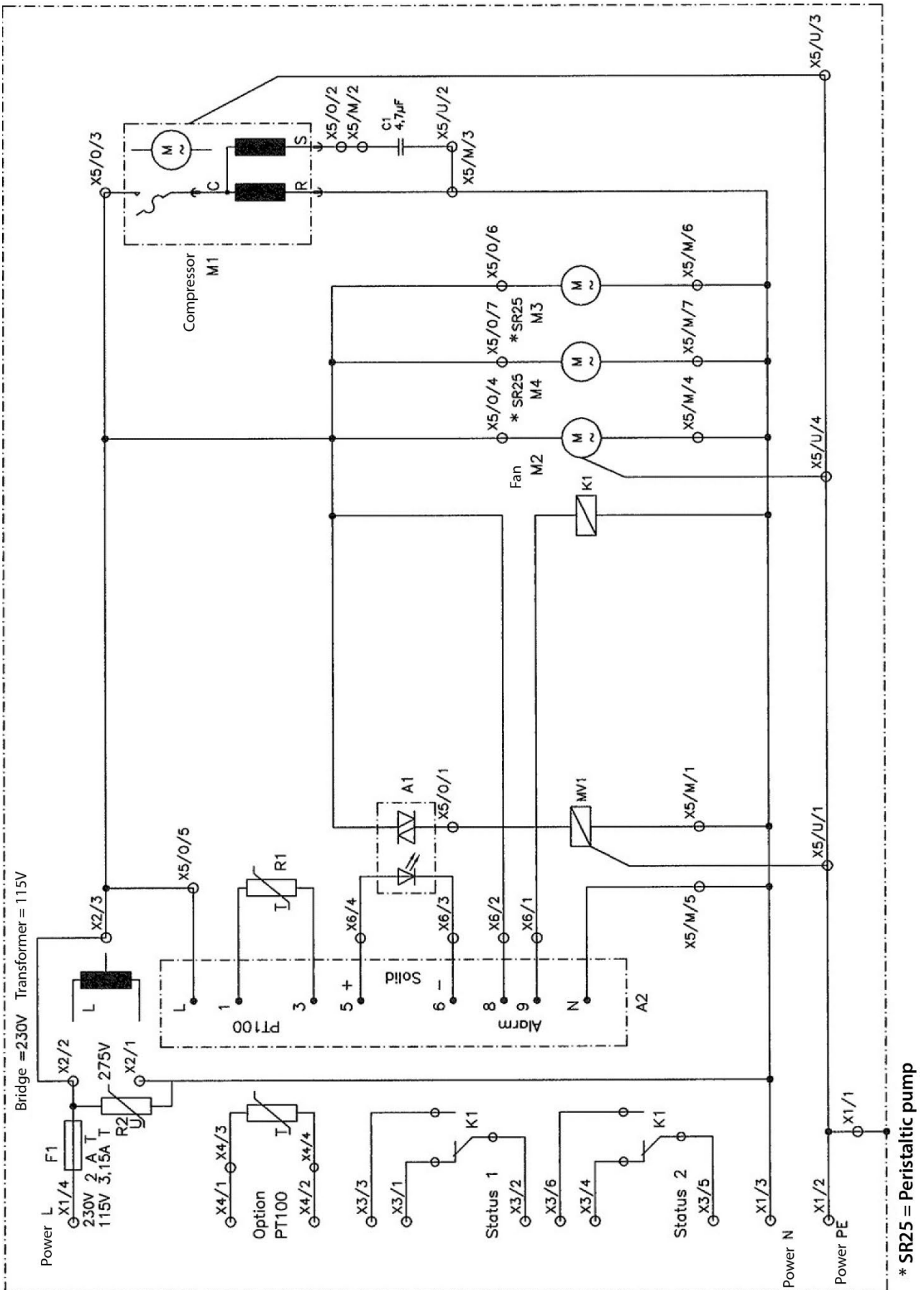

Figure 10 Circuit diagram ECM-ExII (Drawing-No.: 2456-5.01)



Translation

1 Type Examination Certificate

2 **Equipment or Protective System intended for use in potentially explosive atmospheres
Directive 2014/34/EU**

3 Type Examination Certificate Number: **BVS 16 ATEX E 055 X**

4 Product: **Gas cooler type ECM-EXII**

5 Manufacturer: **M&C TechGroup Germany GmbH**

6 Address: **Rehhecke 79, 40885 Ratingen, Germany**

7 This product and any acceptable variations thereof are specified in the appendix to this certificate and the documents referred to therein.

8 DEKRA EXAM GmbH certifies that this product has been found to comply with the Essential Health and Safety Requirements relating to the design and construction of products intended for use in potentially explosive atmospheres given in Annex II to the Directive.
The examination and test results are recorded in the confidential Report No. BVS PP 16.2136 EU.

9 Compliance with the Essential Health and Safety Requirements has been assured by compliance with:

**EN 60079-0:2012 + A11:2013 General requirements
EN 60079-15:2010 Type of Protection "n"**

Except in respect of those requirements listed under item 18 of the appendix.

10 If the sign "X" is placed after the certificate number, it indicates that the product is subject to the Specific Conditions of Use specified in the appendix to this certificate.

11 This Type Examination Certificate relates only to the design and construction of the specified product. Further requirements of the Directive apply to the manufacturing process and supply of this product. These are not covered by this certificate.

12 The marking of the product shall include the following:

Ex II 3G Ex nA nC IIC T4 Gc

DEKRA EXAM GmbH
Bochum, 2016-08-08

Signed: Dr. Franz Eickhoff

Certifier

Signed: Ute Hauke

Approver



Page 1 of 3 of BVS 16 ATEX E 055 X
This certificate may only be reproduced in its entirety and without any change.

DEKRA EXAM GmbH, Dinnendahlstrasse 9, 44809 Bochum, Germany,
telephone +49.234.3696-105, Fax +49.234.3696-110, zs-exam@dekra.com



13 Appendix

14 Type Examination Certificate BVS 16 ATEX E 055 X

15 Product description

15.1 Subject and type

Gas cooler type ECM-EXII

15.2 Description

The gas cooler type ECM-EX II is used for the dew point of humid sample gases in the Analysis technology to prevent condensation in analysers.

The gas cooler may be provided with one or two heat exchangers and with one or two condensate pumps.

The gas cooler type ECM-EXII consists of a hermetically sealed cooling circuit of the type of protection nC with an electrical connection of type of protection nA.

The functional components of the control unit are also carried out in type of protection n.

15.3 Parameters

15.3.1 Electrical data

Rated voltage	115/230	VAC, 50-60 Hz
Rated current	4.5/ 2.5	A
Rated powermax.	200	VA

15.3.2 Thermal data

Ambient temperature range	+10 °C up to +50 °C
Maximum sampling gas input temperature	130 °C

15.3.3 Other data

Maximum coolant operating pressure	18 bar
Coolant	R134a

Page 2 of 3 of BVS 16 ATEX E 055 X

This certificate may only be reproduced in its entirety and without any change.



DEKRA EXAM GmbH, Dinnendahlstrasse 9, 44809 Bochum, Germany,
telephone +49.234.3696-105, Fax +49.234.3696-110, zs-exam@dekra.com



16 **Report Number**

BVS PP 16.2136 EU, as of 2016-08-08

17 **Special Conditions for Use**

The equipment has to be installed in a protective enclosure which meets the requirements for IP54 defined in EN 60079-0 clause 26.4.

18 **Essential Health and Safety Requirements**

The Essential Health and Safety Requirements are covered by the standards listed under item 9.

19 **Drawings and Documents**

Drawings and documents are listed in the confidential report.

We confirm the correctness of the translation from the German original.
In the case of arbitration only the German wording shall be valid and binding.

DEKRA EXAM GmbH
Bochum, dated 2016-08-08
BVS-Pe/Nu A 20160276

Certifier

Approver



Page 3 of 3 of BVS 16 ATEX E 055 X
This certificate may only be reproduced in its entirety and without any change.

DEKRA EXAM GmbH, Dinnendahlstrasse 9, 44809 Bochum, Germany,
telephone +49.234.3696-105, Fax +49.234.3696-110, zs-exam@dekra.com



1 Baumusterprüfbescheinigung

2 **Geräte und Schutzsysteme zur bestimmungsgemäßen
Verwendung in explosionsgefährdeten Bereichen
Richtlinie 2014/34/EU**

3 Nr. der Baumusterprüfbescheinigung: **BVS 16 ATEX E 055 X**

4 Produkt: **Gaskühler Typ ECM-EXII**

5 Hersteller: **M&C TechGroup Germany GmbH**

6 Anschrift: **Rehhecke 79, 40885 Ratingen, Deutschland**

7 Die Bauart dieses Produktes sowie die verschiedenen zulässigen Ausführungen sind in der Anlage zu dieser Baumusterprüfbescheinigung festgelegt.

8 Die Zertifizierungsstelle der DEKRA EXAM GmbH bescheinigt, dass das Produkt die wesentlichen Gesundheits- und Sicherheitsanforderungen für die Konzeption und den Bau von Produkten zur bestimmungsgemäßen Verwendung in explosionsgefährdeten Bereichen gemäß Anhang II der Richtlinie erfüllt.
Die Ergebnisse der Prüfung sind in dem vertraulichen Prüfprotokoll BVS PP 16.2136 EU niedergelegt.

9 Die wesentlichen Gesundheits- und Sicherheitsanforderungen werden erfüllt durch Übereinstimmung mit den Normen:

**EN 60079-0:2012 + A11:2013 Allgemeine Anforderungen
EN 60079-15:2010 Zündschutzart "n"**

10 Falls das Zeichen „X“ hinter der Bescheinigungsnummer steht, wird in der Anlage zu dieser Bescheinigung auf besondere Bedingungen für die sichere Anwendung des Produktes hingewiesen.

11 Diese Baumusterprüfbescheinigung bezieht sich nur auf den Entwurf und Bau der beschriebenen Produkte.
Für den Herstellungsprozess und die Abgabe der Produkte sind weitere Anforderungen der Richtlinie zu erfüllen, die nicht durch diese Bescheinigung abgedeckt sind.

12 Die Kennzeichnung des Produktes muss die folgenden Angaben enthalten:

Ex II 3G Ex nA nC IIC T4 Gc

DEKRA EXAM GmbH
Bochum, den 08.08.2016



Zertifizierer



Fachzertifizierer



Seite 1 von 2 zu BVS 16 ATEX E 055 X
Dieses Zertifikat darf nur vollständig und unverändert weiterverbreitet werden.

DEKRA EXAM GmbH, Dinnendahlstraße 9, 44809 Bochum, Deutschland
Telefon +49.234.3696-105, Telefax +49.234.3696-110, zs-exam@dekra.com



13 Anlage zur

14 Baumusterprüfbescheinigung BVS 16 ATEX E 055 X

15 Beschreibung des Produkts

15.1 Gegenstand und Typ

Gaskühler Typ ECM-EXII

15.2 Beschreibung

Der Gaskühler Typ ECM-EXII dient zur Taupunktabsenkung von feuchten Messgasen in der Analysetechnik, um Kondensation in Analysegeräten auszuschließen.

Der Gaskühler kann mit ein oder zwei Wärmetauschern und mit bis zu zwei Kondensatpumpen bestückt werden.

Der Gaskühler Typ ECM-EXII besteht aus einem hermetisch verschlossenen Kühlkreislauf in der Zündschutzart nC mit einem elektrischen Anschluss in der Zündschutzart nA.

Die Funktionskomponenten der Steuerung sind ebenfalls in der Zündschutzart n ausgeführt.

15.3 Kenngrößen

15.3.1 Elektrische Daten

Bemessungsspannung		115/230	VAC, 50-60 Hz
Bemessungsstromstärke		4,5/ 2,5	A
Bemessungsleistung	max.	200	VA

15.3.2 Thermische Daten

Umgebungstemperaturbereich	+10 °C bis +50 °C
Maximale Messgaseintrittstemperatur	130 °C

15.3.3 Weitere Daten

Maximaler Betriebsdruck Kältemittel	18 bar
Kältemittel	R134a

16 Prüfprotokoll

BVS PP 16.2136 EU, Stand 08.08.2016

17 Besondere Bedingungen für die Verwendung

Das Gerät muss in ein Schutzgehäuse eingebaut werden, dass dem Schutzgrad IP54 nach EN 60079-0, Abschnitt 26.4 entspricht.

18 Wesentliche Gesundheits- und Sicherheitsanforderungen

Die wesentlichen Gesundheits- und Sicherheitsanforderungen sind durch die unter Abschnitt 9 gelisteten Normen abgedeckt.

19 Zeichnungen und Unterlagen

Die Zeichnungen und Unterlagen sind in dem vertraulichen Prüfprotokoll gelistet.



Seite 2 von 2 zu BVS 16 ATEX E 055 X
Dieses Zertifikat darf nur vollständig und unverändert weiterverbreitet werden.

DEKRA EXAM GmbH, Dinnendahlstraße 9, 44809 Bochum, Deutschland
Telefon +49.234.3696-105, Telefax +49.234.3696-110, zs-exam@dekra.com



Certificate of Compliance

Certificate: 1830717

Master Contract: 222408

Project: 70091348

Date Issued: May 18, 2017

Issued to: M&C TechGroup Germany GmbH
Rehhecke 79
40885 Ratingen
GERMANY
Attention: Fabian Groß

The products listed below are eligible to bear the CSA Mark shown



Issued by: *Herbert Peters*
Herbert Peters

PRODUCTS

CLASS 2258-02 PROCESS CONTROL EQUIPMENT-For Hazardous Locations-

Class I, Division 2, Groups A, B, C and D

Electric gas cooler, Model ECM, ECM-ExII, Permanently connected, rated 120 V, 60 Hz or 240 V, 50 Hz, 200 VA

Temperature Code T4 for an ambient temperature of +50°C

APPLICABLE REQUIREMENTS

CAN/CSA-C22.2 No. 61010.1-04

Safety Requirements for Electrical Equipment for Measurement, Control and Laboratory Use, Part 1; General Requirements

CAN/CSA-C22.2 No. 213-M87

Non-Incendive Electrical Equipment for Use in Class I, Division 2 Hazardous Locations



Certificate: 1830717
Project: 70091348

Master Contract: 222408
Date Issued: May 18, 2017

MARKINGS

The following markings appear on the product:

1. Submitter's identification (company name and/or file number and/or registered tradename);
2. Model designation;
3. Date of manufacture (or traceable serial number);
4. The CSA Monogram;
5. Hazardous area: Class I, Division 2, Groups A, B, C and D, T4;
6. Ambient temperature range;
7. Electrical ratings
8. The warning sign “⚠” in a triangle, referring to the manual for further details about installation and operation of the equipment



Supplement to Certificate of Compliance

Certificate: 1830717

Master Contract: 222408

*The products listed, including the latest revision described below,
are eligible to be marked in accordance with the referenced Certificate.*

Product Certification History

Project	Date	Description
70091348	May 18, 2017	Minor changes of the marking, new material of the adhesive label material and an additional cover over the controller buttons. No additional tests required.
2501569	January 10, 2013	Alternative approved critical components: Fuse holder, fuse F1 and ventilator M2. No additional tests required
1830717	September 04, 2006	Original CSA Certification for Electric Gas Cooler models ECM, ECM-ExII